

# MODEL 4SP21ELR PLUNGER PUMP



## 2.1 GPM – 2,000 PSI

### Compact Direct Drive Pump with Integral Pressure Regulator

When it comes to getting the job done, customers rely on durable long-lasting products from Cat Pumps and the 4SP is no exception. Designed for continuous duty applications, the 4SP series pumps are built to the same high standards as all Cat Pumps products.

Cat Pumps engineers have optimized every detail to produce a pump with incredible service life. Concentric high-density polished solid plungers provide a true wear surface resulting in extended seal life. The integral pressure regulator and standard 56C NEMA mounting makes the pump easy to integrate into high pressure systems. The 4SP21ELR is what you expect from Cat Pumps — high quality, dependable products backed by the industry's best customer service and support.

#### Features

- Specially formulated high-pressure seals and concentric, polished ceramic plungers provide maximum seal life, keeping equipment running longer with less downtime
- Stacked valve design makes service even easier
- Direct drive hollow shaft mounts to standard 56C frame electric motors for convenient and worldwide use
- Integral pressure regulator with built in by-pass for compact size and easy plumbing

#### Typical Applications

- Misting and fogging for cooling
- Humidification
- Pressure washing

## Specifications

	US Measure	Metric Measure
<b>Flow</b>	2.1 gpm	7.9 lpm
<b>Pressure</b>	100 to 2,000 psi	7 to 138 bar
<b>RPM</b>	1750 rpm	1750 rpm
<b>Shaft Diameter</b>	5/8"	15.9 mm
<b>Inlet Pressure Range</b>	Tank fed to 60 psi	Tank fed to 4 bar
<b>Max. Liquid Temperature</b>	140° F	60° C
<b>Inlet Port (1)</b>	3/8" NPT(F)	3/8" NPT(F)
<b>Accessory Inlet Port (1)</b>	1/4" NPT(F)	1/4" NPT(F)
<b>Discharge Ports (3)</b>	3/8" NPT(F)	3/8" NPT(F)
<b>Weight</b>	10.6 lbs	4.8 kg
<b>Dimensions</b>	7.8 x 6.7 x 5.3"	198 x 171.5 x 134 mm

Note: Direct-drive hollow shaft mounts to a standard 56C motor.

## Dimensions

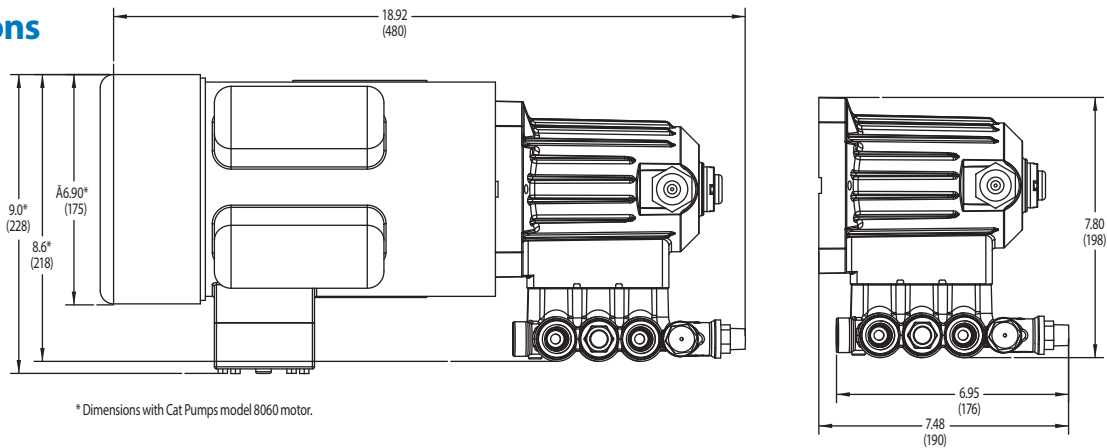

## Popular Accessories



### Pop-Off Valve

PN 30961  
1 – 6 gpm  
1,000 – 3,000 psi



### Pressure Gauge

PN 6088  
0 – 3,000 psi



### Inlet Strainer

PN 7204.4  
1/2" NPT(F)  
10 gpm



### Pump Protector

PN 6208  
Case of 6, 12 oz. bottles



### Oil

PN 6107  
21 oz. Bottle  
Specially formulated for  
extended protection

Contact Cat Pumps for pricing or more information at [techsupport@catpumps.com](mailto:techsupport@catpumps.com) or 763-780-5440

Application photo courtesy of Atomizing Systems Inc.



### CAT PUMPS

1681 - 94TH LANE N.E. MINNEAPOLIS, MN 55449-4324  
PHONE (763) 780-5440 — FAX (763) 780-2958  
e-mail: [techsupport@catpumps.com](mailto:techsupport@catpumps.com)  
[www.catpumps.com](http://www.catpumps.com)

For International Inquiries go to [www.catpumps.com](http://www.catpumps.com) and navigate to the "Contact Us" link.

©2015 Cat Pumps All rights reserved. 995EL004 Rev A 3/15