

# DATA SHEET

## DIRECT DRIVE GEARBOXES



### Models:

**8065, 8068** Used on Model 45 Pumps

**8071, 8078** Used on Model 56, 60, 700, 740, 760, 781 Pumps

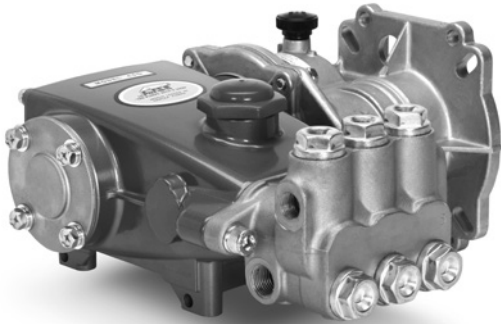

Model 45G1 Shown

SPECIFICATIONS	U.S. Measure	Metric Measure
Gear Ratio	2.04 to 1	2.04 to 1
Mounting Face	6-1/2"	165 mm
Engine Shaft Diameter:		
8065, 8071	1"	25.4 mm
8068, 8078	1-1/8"	28.5 mm
Engine Shaft Length	3-1/4"	82.6 mm
Gearbox Capacity	10 oz.	0.30 l
Weight		
8065, 8068	4.2 lbs.	1.90 kg
8071, 8078	7.5 lbs.	3.40 kg
Dimensions	6.42 x 4.53 x 8.19"	163 x 115 x 208 mm

Mounting Flange: SAE J609, Flange B, Extensions 4 (1" Ø) or 4a (1-1/8" Ø), Shaft length = 3-1/4", Pilot Ø = 5-3/4", B.C. Ø = 6-1/2", Thread = 3/8" - 16UNC Tap

### GEARBOX FEATURES

- No pulley selection or adjustment for quick, easy gas engine mounting.
- Totally sealed housing providing independent gearbox lubrication for maximum service life.
- Hardened steel helical design gears for smooth, quiet operation.
- Multiple engine shaft and flange options for flexibility.

# EXPLODED VIEW

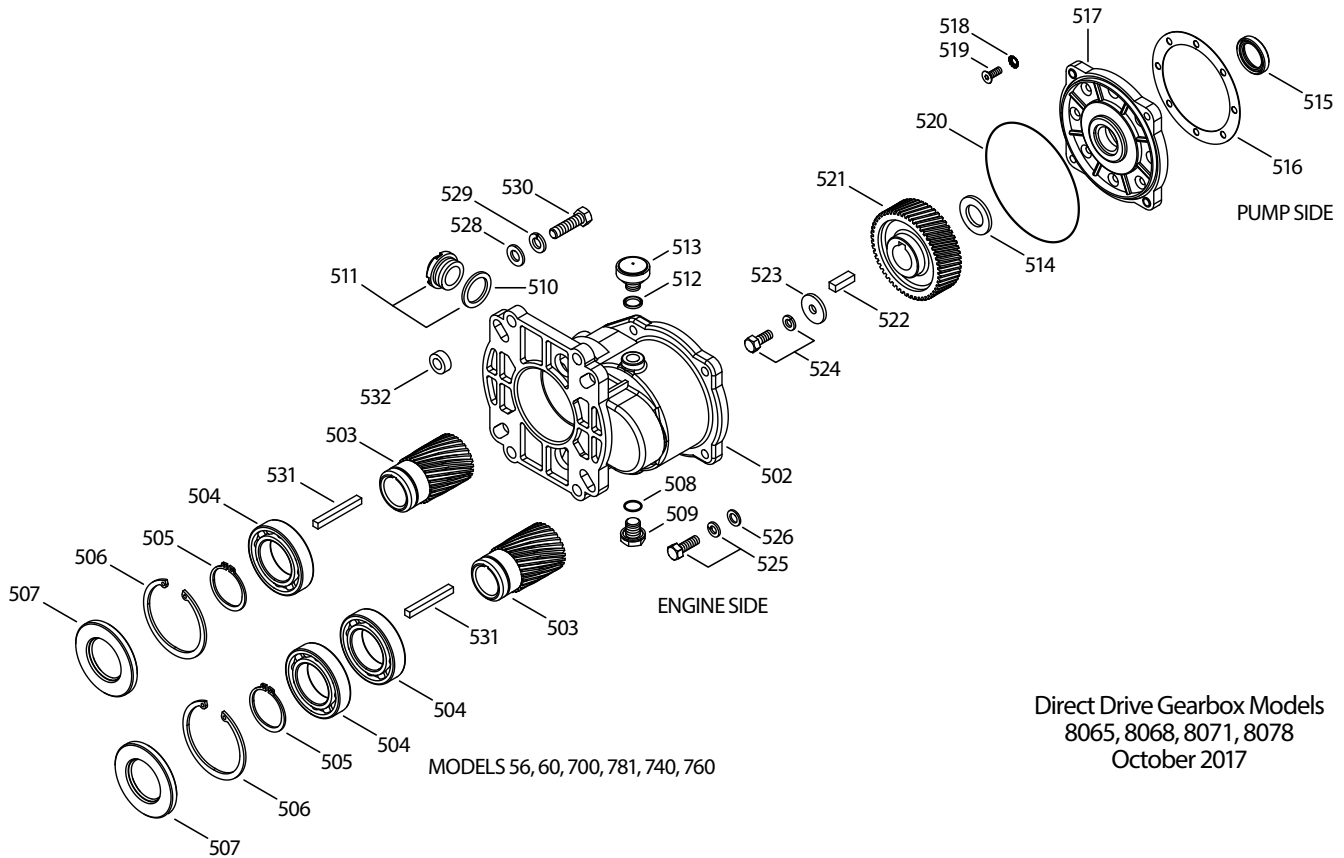

## PARTS LIST

PART ITEM NUMBER	MATL	DESCRIPTION	GEARBOX MODEL	QTY.	PART ITEM NUMBER	MATL	DESCRIPTION	GEARBOX MODEL	QTY.		
502	44673	AL	Housing	8065, 8068	1	46122	AL	Flange, Bearing Cover (M8)	8065, 8068	1	
	45351	AL	Housing	8071, 8078	1	518	126745	STCP R	Lockwasher, Conical (M6)	8071, 8078	4/8
503	44675	STL	Gear, Pinion (1")	8065	1	126746	STCP R	Lockwasher, Conical (M8)	8065, 8068	4	
	45352	STL	Gear, Pinion (1")	8071	1	519	45763	STZP	Screw, Hex Socket Flat Head (M6x16)	8011, 8078	4
	44690	STL	Gear, Pinion (1-1/8")	8068	1		46124	STL	Screw, Hex Socket Flat Head (M8x16)	8065, 8068	4
	45358	STL	Gear, Pinion (1-1/8")	8078	1	520	14045	NBR	O-Ring, Flange	All Models	1
504	56110	STL	Bearing, Ball	All Models	1/2	521	44680	STL	Gear, Helical Drive	8071, 8078	1
505	55459	STL	Retainer, Ring (External)	All Models	1		44711	STL	Gear, Helical Drive	8065, 8068	1
506	146423	STL	Retainer, Ring (Internal)	All Models	1	522	44459	STL	Key (M8x7x24)	8071, 8078	1
507	44676	NBR	Seal, Oil Case, Pinion	All Models	1		101814	STL	Key (M6x6x27)	8065, 8068	1
508	23170	NBR	O-Ring, Drain Plug	All Models	1	523	126579	STZP R	Washer, Flat Holding	All Models	1
509	25625	STCP	Plug, Oil Drain (1/4"-19 BSP)	All Models	1	524	92521	STZP	Screw, Sems Hex Head Retaining (M8x20)	All Models	1
510	44428	NBR	Gasket, Flat Flex, Oil Gauge	All Models	1	525	92530	STZP	Screw, Sems Hex Head (M8x25)	All Models	4
511	92241	—	Gauge, Bubble Oil w/Gasket	All Models	1	526	126573	STCP R	Washer, Flat (M8)	All Models	4
512	103685	NBR	Gasket, Flat Flex, Oil Cap	All Models	1	528	126574	STZP R	Washer, Flat (M10)	All Models	4
513	44374	—	Cap, Oil Filler	All Models	1	529	126231	STCP R	Lockwasher, Split (M10)	All Models	4
514	20129	STZP	Washer (M20)	8065, 8068	1	530	126543	STCP R	Screw, Hex Head (3/8-16 x 1-3/8")	All Models	4
515	44679	NBR	Seal, Oil, Bearing Cover Flange	All Models	1	531	44455	STL	Key (1/4" x 1/4" x 2-5/32")	All Models	1
516	45759	—	Gasket, Flange	8071, 8078	1	532	34042	AL	Spacer	All Models	4
	46121	—	Gasket, Flange	8065, 8068	1						
517	45934	AL	Flange, Bearing Cover	8071, 7078	1						

R Components comply with RoHS Directive

MATERIAL CODES (Not Part of Part Number): AL=Aluminum NBR=Medium Nitrile (Buna-N) S=304SS STL=Steel STCP=Steel/Chrome Plated STZP=Steel/Zinc Plated

Before you begin servicing your pump, **Please carefully read OPERATOR'S MANUAL and separate SERVICE MANUAL** for special lubrication, disassembly and reassembly information.

## SERVICING THE GEARBOX

### DISASSEMBLY

1. Completely drain lube from gearbox housing.
2. Remove the four (4) hex head combination (HHC) screws which fasten the gearbox to the engine and separate gearbox and pump from engine.
3. Remove the four (4) HHC screws which fasten the gearbox to the bearing cover flange and separate gearbox housing from pump.
4. Place gearbox housing on work surface with seal facing up.
5. Remove pinion oil seal by inserting screwdriver between pinion gear and inner lip of seal and pry out. **NOTE:** Seal will be damaged and must be replaced.
6. Remove large retaining ring in groove below the pinion oil seal using retaining ring pliers and set aside for re-use.
7. Remove the pinion gear and bearing. Turn gearbox housing over onto engine mount flange surface. Bearing is pressed into position so it is necessary to press pinion and bearing out from rear. Set gearbox housing aside.
8. Remove bearing from pinion gear. Using reverse pliers remove retaining ring from groove on pinion gear and press bearing from pinion. Set aside pinion, bearing and retaining ring.
9. Remove hex machined retaining screw, lockwasher and flat holding washer from center of helical drive gear on pump shaft.
10. Slip helical drive gear from crankshaft.
11. Remove key from keyway in pump crankshaft. At this point the gearbox has been disassembled. Now begin examination of the gearbox parts for wear and reassembly. While the gearbox is in this state of disassembly, it is advisable to examine your pump for any indication of drive-end wear.

If any of the following conditions are present, removal of the bearing cover flange is necessary. Only trained technicians should service drive end.

- Leakage between bearing cover flange and pump crankcase.
- Evidence of water in pump crankcase.
- Evidence of water in gearbox crankcase.

**NOTE:** If removal of bearing cover flange is necessary, completely drain oil from crankcase of pump.

### REMOVING BEARING COVER FLANGE

1. Remove the hex socket head (HSH) screws, lockwashers and washers from bearing cover flange.
2. Tap flange with soft mallet to separate from pump crankcase.
3. Examine pump bearing and replace if worn.
4. Examine oil seal in bearing cover flange and replace if worn.
5. Examine gasket on outside of bearing cover flange and replace if cut or cracked.
6. Examine o-ring on inside outer groove of bearing cover flange and replace if cut or worn. If further pump servicing is needed, refer to your pump service manual, and Tech Bulletin 035 on "Servicing Crankcase Section".

### REPLACING BEARING COVER FLANGE

1. Line up the four holes and mount gasket on outside of bearing cover flange. **NOTE:** Models 56, 60 and 700 have dual bearings and eight screws.
2. Press new seal into bearing cover flange after exercising caution not to cut seal on keyway edge.
3. Line up the inside mounting holes on bearing cover flange with the holes on the pump. Keep the two outer "flanged" mounting holes to the top rear and lower front.
4. Apply Loctite®-242® to the threaded area of screws before replacing. Torque per chart.

### REASSEMBLY

1. Insert key into pump crankshaft keyway until flush with end of shaft.
2. Examine helical drive gear teeth for wear and replace if necessary. Line up keyway on gear with pump shaft keyway and key and slide onto shaft.
3. Install flat holding washer, lockwasher and retaining screw onto shaft and torque per chart.
4. Examine gearbox oil gauge and oil drain plug for any evidence of leaking and replace o-ring and gasket if necessary.
5. Examine pinion bearing for wear and replace if necessary.
6. Examine pinion gear teeth for wear and replace if necessary.
7. Press bearing over pinion gear until seated on shoulder. (Models with dual bearings; press first bearing on until seated; then second bearing until seated up to first bearing.)
8. Install retaining ring on pinion gear and snap into groove.
9. Insert pinion and gear assembly into gearbox housing and press into position until seated on shoulder. Groove for large retaining ring must be visible.
10. Insert large retaining ring into pinion bearing housing and snap into groove.
11. Lubricate I.D. and O.D. of new pinion oil seal. Place oil seal at mouth of pinion bearing housing with garter spring facing down. Carefully press seal into position until seated on retaining ring. Keep seal square in position to avoid inner lip hanging up on pinion gear edge.
12. Rotate pinion gear so keyway is up. Mount assembled gearbox housing onto pump shaft with helical drive gear.

**NOTE:** Carefully match gear teeth and line up mounting holes. Place engine mounting flange in forward position.

13. Install the screws to fasten gearbox to bearing cover flange. Torque per chart.

Loctite and 242 are registered trademarks of Henkel Corporation.

## MOUNTING PUMP WITH GEARBOX ONTO ENGINE

1. Rotate crankshaft of engine until keyway is at top.
2. Insert key into keyway and generously apply Loctite 76764 antiseize lubricant to engine shaft.
3. Line up keyway of pinion gear and engine shaft and carefully slip gearbox onto engine shaft until flush with engine face. Install four (4) hex machined screws. Torque per chart.

**NOTE:** Due to varying engine shaft lengths it may be necessary to install a small spacer on each of the four (4) hex machined screws between gearbox flange and engine face.

4. Before starting operation, fill gearbox housing to oil gauge dot with 80-90 weight gear lube (PN 6110) and fill crankcase of pump to oil gauge dot with Cat Pumps Special Premium Grade Non-detergent Oil (PN 6107).

### FIELD CONVERSION FROM STANDARD PUMP

To convert from a standard pump to a gearbox pump, remove the existing bearing cover, gasket and four (4) HHC combination head screws. Replace with new gearbox bearing cover flange, gasket, four (4) lockwashers and new hex socket flat head screws.

The bearing for the 56 and 60 pumps is a tapered roller bearing with outer race. Remove the standard bearing cover from the pump. Remove outer race from bearing cover by gently pounding on work surface to unseat. Then use a bearing puller tool to pull race from bearing cover. Next press outer race into gearbox bearing cover flange. Be certain race is completely seated in flange before mounting onto pump.

## TORQUE CHART

Description	Thread	Tool	Torque
Gearbox Housing to Bearing Cover Flange	M8	13 mm	70 in. lbs. (8 Nm)
Bearing Cover Flange to Pump (M6)	M6	4 mm	70 in. lbs. (8 Nm)
Bearing Cover Flange to Pump (M8)	M8	5 mm	125 in. lbs. (15 Nm)
Drive Gear Retaining Screw	M8	13 mm	110 in. lbs. (12 Nm)
Engine Mounting Screw	3/8-16	14 mm	110 in. lbs. (12 Nm)

## DIMENSIONAL

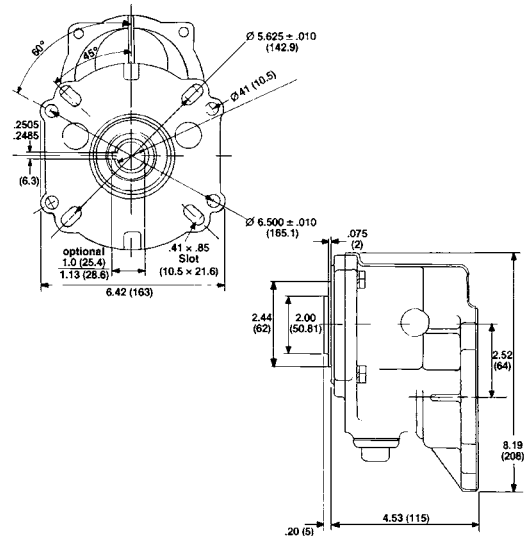

**Model  
45G1**

## DIMENSIONAL

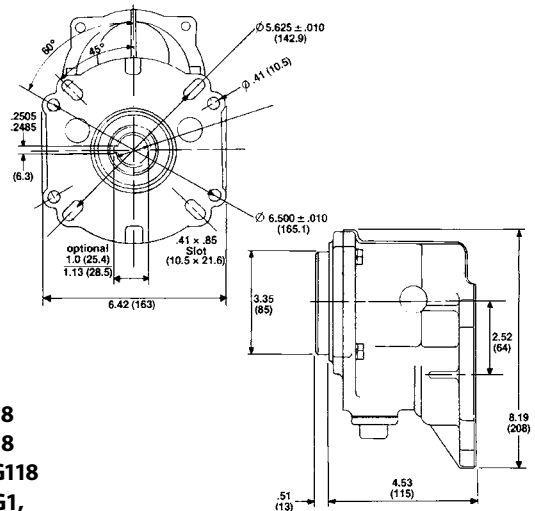

**Models  
56G1, 56G118  
60G1, 60G118  
700G1, 700G118  
740G1, 760G1,  
781G1**

### ⚠ CAUTIONS AND WARNINGS

All High Pressure Systems require a primary pressure regulating device (i.e. regulator, unloader) and a secondary pressure relief device (i.e. pop-off valve, relief valve). Failure to install such relief devices could result in personal injury or damage to pump or property. Cat Pumps does not assume any liability or responsibility for the operation of a customer's high pressure system.

Read all CAUTIONS and WARNINGS before commencing service or operation of any high pressure system. The CAUTIONS and WARNINGS are included in each service manual and with each Accessory Data sheet. CAUTIONS and WARNINGS can also be viewed online at [www.catpumps.com/cautions-warnings](http://www.catpumps.com/cautions-warnings) or can be requested directly from Cat Pumps.

### WARRANTY

View the Limited Warranty on-line at [www.catpumps.com/warranty](http://www.catpumps.com/warranty).



#### CAT PUMPS

1681 - 94TH LANE N.E. MINNEAPOLIS, MN 55449-4324  
PHONE (763) 780-5440 — FAX (763) 780-2958  
e-mail: [techsupport@catpumps.com](mailto:techsupport@catpumps.com)  
[www.catpumps.com](http://www.catpumps.com)