

DATA SHEET

PRESSURE-SENSITIVE REGULATING UNLOADER



Brass Model: 7593



FEATURES

- Provides system pressure control and protection for single or multiple gun applications.
- Maintains full system pressure while running in bypass with minimal load on pump.
- Minimum pressure fluctuations with alternating use of multiple guns.
- Easy external pressure adjustment with locking nut to prevent over-pressurization.
- Lightweight flow-through design for compact installation.

SPECIFICATIONS	U.S. Measure	Metric Measure
Flow Range	10–52.8 gpm	38–200 lpm
Pressure Range	406–4060 psi	28–280 bar
Inlet Port	1" BSPP (F)	1" BSPP (F)
Discharge Port	1" BSPP (F)	1" BSPP (F)
ByPass Port	1" BSPP (F)	1" BSPP (F)
Maximum Temperatures (NBR)	140° F	60° C
Weight	7.6 lbs	3.4 kg
Dimensions	10.2 x 5.0 x 2.2"	259 x 129 x 55 mm

Note: Use only at above specifications to ensure proper unloader life performance

 This Pressure-Sensitive Regulating Unloader can be converted to a Secondary Relief Valve. See page 4 for Relief Valve conversion.

Read all CAUTIONS and WARNINGS before commencing service or operation of any high-pressure system

SELECTION

This pressure-sensitive regulating unloader is designed for systems with single or multiple pumps, solenoid (gate) valves, nozzles, and shut-off or weep guns.

Note: For multiple-pump systems, it is best to use a pressure regulator, not a pressure-sensitive regulating unloader.

This unloader should meet both the desired system flow (combined nozzle flow rate requirement) and the desired system pressure.

NOTICE Operation below the minimum flow of the unloader causes the unloader to cycle. Operation above the maximum rated flow of the unloader causes cycling and premature unloader wear, preventing achieving the desired system pressure.

INSTALLATION

This unloader operates properly when mounted in any direction. However, keeping the plumbing to a minimum and the pressure adjuster easily accessible is preferred. The ideal mounting location is directly on the pump's discharge manifold.

The inlet connection is a 1" BSPP(F) port located on the backside. There is an arrow and the word IN marked on the body, indicating the direction of flow. Liquid from the discharge of the pump goes into this connection.

The discharge connection is a 1" BSPP(F) port located on the front side (hex end). There is an arrow and the word OUT marked on the body, indicating the direction of flow. Plumbing to the spray guns, solenoid (gate) valves or nozzles connects here.

The bypass connection is a 1" BSPP(F) port located on the bottom. There is an arrow and the word BY-PASS marked on the body, indicating the direction of flow. Bypass liquid is directed out of this port and can be routed to a reservoir (preferred method), drain or pump inlet.

OPERATION

This unloader holds established system pressure in the discharge line when the trigger gun or solenoid (gate) valve is closed, or the nozzle is clogged, thus bypassing all unrequired flow. Squeezing the trigger gun or opening the solenoid (gate) valve will close the bypass and return to established system pressure.

PRESSURE ADJUSTMENT

Note: Pressure is not set at the factory.

1. Setting and adjusting the unloader pressure must be done while the system is running.
2. Start the system with unloader backed off to the lowest pressure setting (counterclockwise direction).
3. Increase the unloader pressure setting by turning the pressure adjuster clockwise.
4. Squeeze the trigger and read the pressure on the gauge at the pump.

Note: Do not read the pressure at the gun or nozzle.

5. If more pressure is desired, release the trigger, turn pressure adjuster one quarter turn in clockwise direction.
6. Squeeze the trigger and read the pressure.
7. Repeat this process until desired system pressure is reached.
8. If desired system pressure cannot be reached, review TROUBLESHOOTING chart.

NOTICE A secondary pressure safety relief device (e.g. pop-off valve, relief valve) should be used along with this pressure-sensitive regulating unloader. Final adjustment for the secondary relief valve should be approximately 200 psi above the system operating pressure.

Note: A minimum of 5% of the flow through the unloader should bypass for proper regulator performance. If the entire unloader flow pumps through the nozzle (zero-bypass), the valve can easily be set for pressure higher than the desired pressure, causing a malfunction or premature wear

Note: By removing the check valve and spring, this unloader can function as a secondary relief valve.

 See page 4 for Relief Valve conversion.

TYPICAL UNLOADER INSTALLATION

1. Relief Valve
(Secondary Pressure Relief Device)
2. Pressure Gauge
3. Triplex Plunger Pump
4. **Pressure-Sensitive Regulating Unloader**
(Primary Pressure Regulating Device)
5. Pulsation Dampener

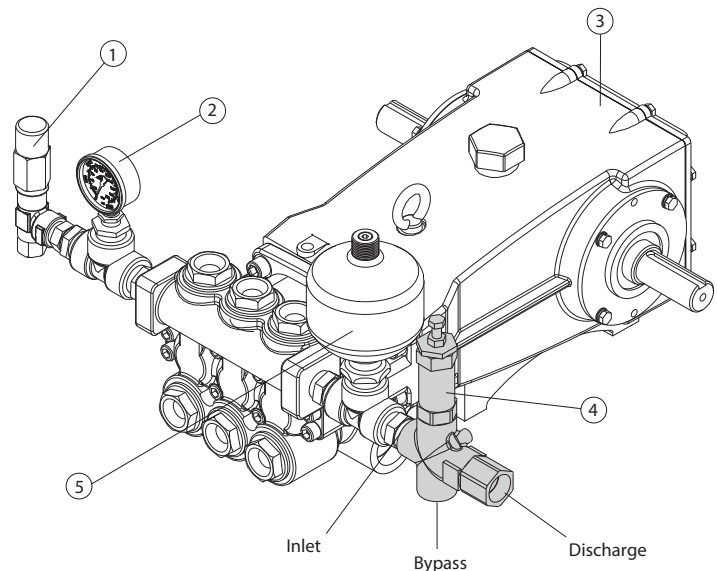

Read all CAUTIONS and WARNINGS before commencing service or operation of any high-pressure system

SERVICING

Disassembly

1. Disconnect bypass, discharge and inlet plumbing from unloader.
 2. Remove unloader from pump.
 3. Secure lower body of unloader in a vise with pressure adjuster facing up.
 4. Remove discharge fitting and O-ring, spring, check valve and O-ring.
 5. Inspect check valve and discharge fitting for wear, spring for wear or fatigue and O-rings for cuts or wear and replace as needed.
- Note:** While the discharge fitting is removed, inspect sealing area for grooves, pitting and wear. Where the check valve makes contact within the internal body of the unloader. If damage is found, stop the repair and replace with complete new unloader. If not, proceed with disassembly.
6. Unscrew and remove pressure adjuster, locking nut, spring retainer, upper spring retainer, spring, lower spring retainer and ball. Inspect all parts for scale build up or wear and replace as needed. Examine spring for fatigue or wear and replace as needed.
 7. Unscrew upper body from lower body.
 8. Secure the valve on the flat surfaces and using an 8 mm allen wrench unthread the piston stem from the valve.
 9. Remove piston retainer, O-rings and backup ring. Examine piston retainer for wear. Examine O-rings and backup ring for cuts or wear and replace as needed.
 10. Examine the valve and piston stem for wear. Examine O-rings and backup rings for cuts or wear and replace as needed.
 11. Press the seat out of the lower body from the bypass port. Examine seat for grooves and O-ring for cuts or wear and replace as needed.

Reassembly

1. Lubricate and install O-ring on outside diameter of seat and press seat squarely into position in the lower body.
2. Lubricate and install O-ring and then backup ring onto piston stem. Press piston stem with threads facing down into the top end of the upper body.
3. Lubricate and install backup ring and then O-ring into inside diameter of piston retainer. Insert piston retainer into the bottom of the upper body.
4. Apply Loctite® 242® to the threads of the piston stem and valve. Thread valve onto piston stem and tighten with wrench.
5. Lubricate and install O-ring on to bottom of the upper body. Carefully hand thread upper body into lower body and tighten with a wrench.
6. Replace the ball, lower spring retainer, spring, upper spring retainer and spring retainer into top of upper body.
7. Thread in locking nut and pressure adjuster.
8. Lubricate and install O-ring onto check valve. Place spring inside check valve. Insert check valve with O-ring and spring into discharge port of lower body.
9. Lubricate and install O-ring onto threaded end of discharge fitting. Thread in discharge fitting to discharge port of lower body and tighten with wrench.
10. Remove unloader from vise.
11. Re-install unloader onto pump.
12. Reconnect bypass, discharge and inlet plumbing to unloader.
13. Proceed to PRESSURE ADJUSTMENT.

Loctite® 242® are registered trademarks of the Henkel Corporation.

TROUBLESHOOTING

Unloader cycles	<ul style="list-style-type: none"> • Check valve O-ring is worn out • Fitting leaking downstream • Air in system, poor connection • Worn O-ring inside gun • Insufficient flow through unloader
Liquid leaking from bottom	<ul style="list-style-type: none"> • Seat or inlet fitting O-ring is cut or worn
Liquid leaking from middle	<ul style="list-style-type: none"> • Piston or piston stem O-ring is worn or cut
Unloader will not come up to pressure	<ul style="list-style-type: none"> • Not properly sized for system pressure • Foreign material in unloader • Piston stem O-rings worn • Nozzle worn or sized incorrectly • Pressure adjuster is not properly set
Extreme pressure spikes	<ul style="list-style-type: none"> • Adjusting handle turned completely into unloader • Restricted bypass or no bypass • System flow exceeds unloader rating

PARTS LIST

ITEM	PN	MATL	DESCRIPTION	QTY
403	—	S	Adjuster, Pressure	1
404	33823	SS	Nut, Lock	1
407	—	BB	Retainer, Spring	1
408	—	STL	Spring	1
409	—	BB	Retainer, Upper Spring	1
410	—	BB	Retainer, Lower Spring	1
412	32776	S	Stem, Piston	1
414	—	PTFE	Backup Ring, Piston Stem	1
415	—	NBR	O-Ring, Piston Stem	1
417	31075	SSSS	Ball, Seat	1
425	—	BB	Body, Upper	1
427	32777	BB	Retainer, Piston	1
428	—	NBR	O-Ring, Piston Retainer	1
429	—	NBR	O-Ring, Piston	1
430	—	PTFE	Backup Ring, Piston	1
431	—	NBR	O-Ring, Piston Retainer	1
435	32774	S	Valve	1
436	32775	S	Seat	1
437	—	NBR	O-Ring, Seat	1
440	—	BB	Body	1
441	—	NBR	O-Ring, Check Valve	1
443	32902	BB	Valve, Check With NBR O-Ring	1
444	32782	S	Spring, Check Valve	1
446	—	NBR	O-Ring, Discharge Fitting	1
460	—	BB	Fitting, Discharge (1" BSPP (F))	1
468	76186	NBR	Kit, O-Ring (Includes: 414, 415, 428–431, 437, 441, 446)	1

Italics are optional items. Material Codes (Not Part of Part No.):

BB=Brass NBR=Medium Nitrile (Buna-N) PTFE=Pure Polytetrafluoroethylene
S=304SS SS=316SS SSSS=440SS STL=Steel

EXPLODED VIEW

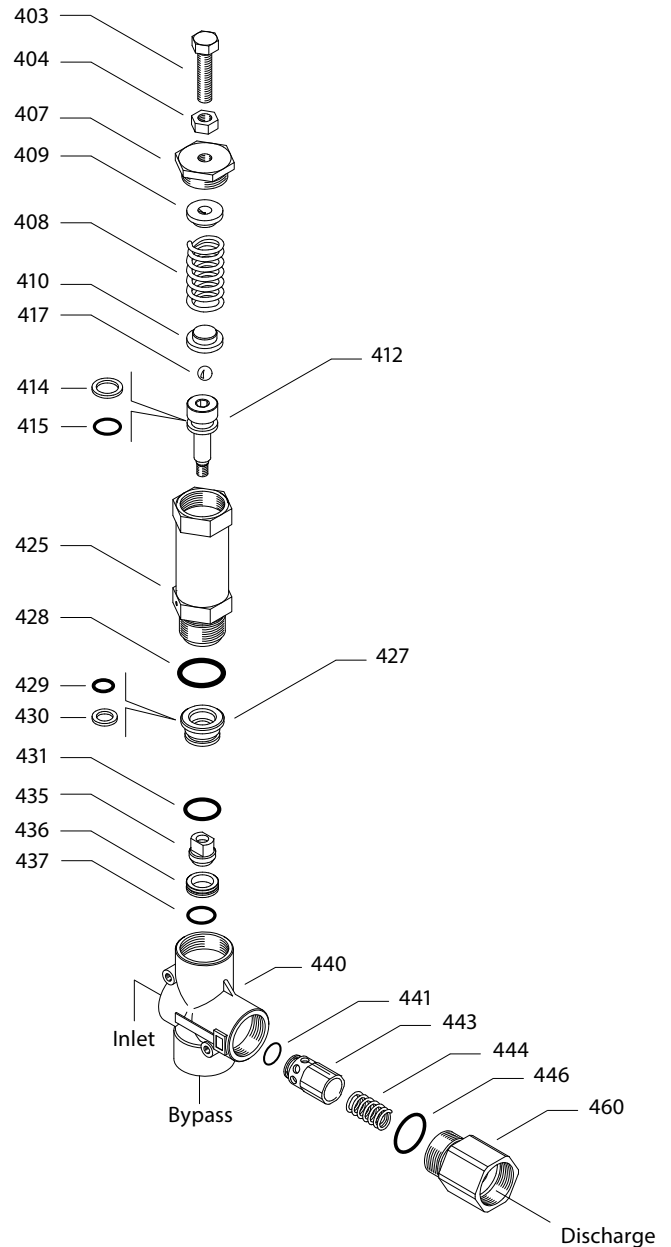

REGULATING UNLOADER TO RELIEF VALVE CONVERSION

The 7593 Pressure-Sensitive Regulating Unloader is typically used as a primary pressure regulating device. It can be converted to a Relief Valve to be used as a secondary pressure relief device by removing the discharge check valve with O-ring and spring.

Unloader PN	Modifications	Converted Relief Valve PN
7593	Remove parts 441, 443, 444	7593.100 (NBR Seals)

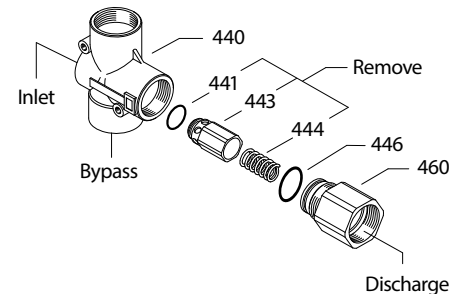

CAUTIONS AND WARNINGS

All high-pressure systems require a primary pressure regulating device (e.g. regulator, unloader) and a secondary pressure relief device (e.g. pop-off valve, relief valve). Failure to install such relief devices could result in personal injury or damage to pump or property. Cat Pumps does not assume any liability or responsibility for the operation of a customer's high-pressure system.

Read all CAUTIONS and WARNINGS before commencing service or operation of any high-pressure system. The CAUTIONS and WARNINGS are included in each Service Manual and with each Accessory Data sheet. CAUTIONS and WARNINGS can also be viewed online at www.catpumps.com/dynamic-literature/cautions-and-warnings or can be requested directly from Cat Pumps.

WARRANTY

View the Limited Warranty online at www.catpumps.com/literature/cat-pumps-limited-warranty