

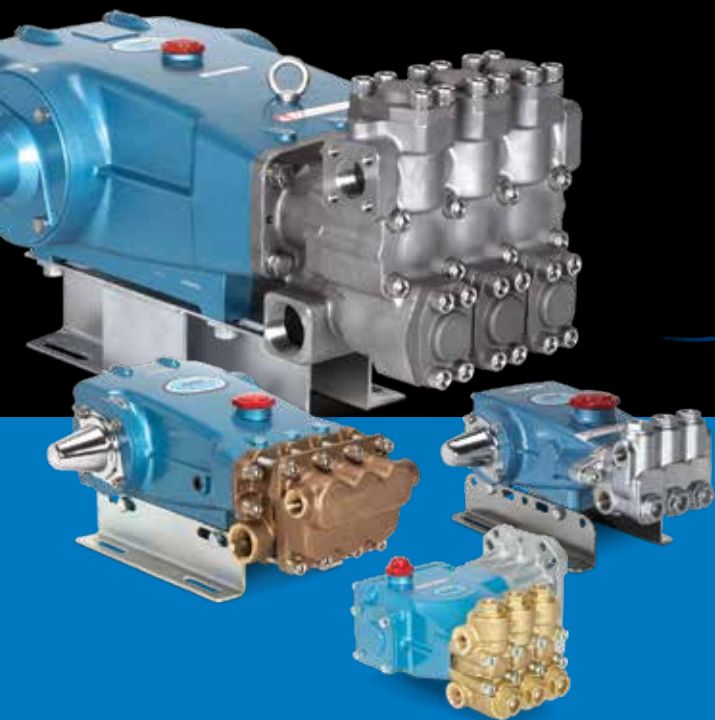

Pump Catalogue

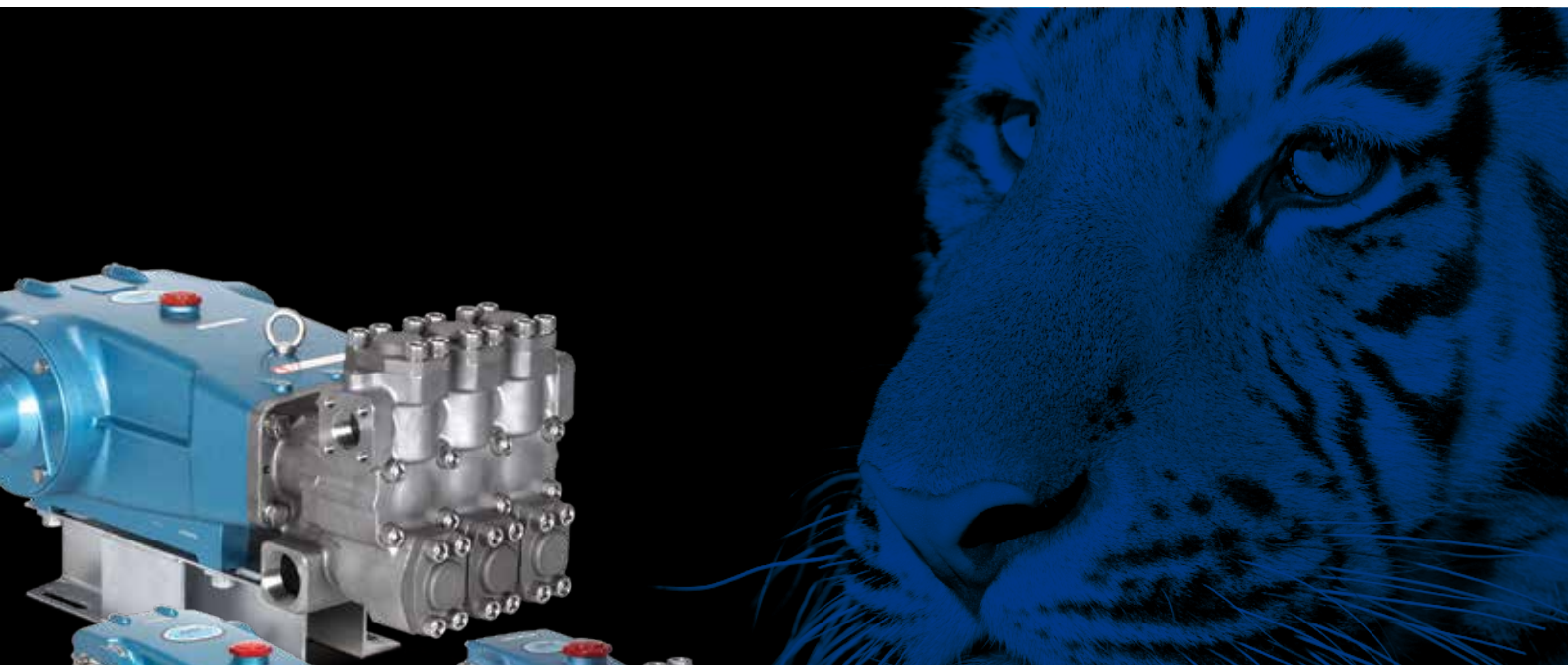

Product Quality, Reliability and Support You Expect

www.catpumps.co.uk

World Leader in Triplex Reciprocating High-Pressure Pumps

Cat Pumps designs and builds products to the highest quality level for one major reason: our customers depend on our products to keep their equipment running. Every design detail is optimised for long product life and reliable performance.

Cat Pumps embraces a zero defect manufacturing philosophy. Stringent process controls result in highly repeatable processes, yielding the highest level of product reliability. Cat Pumps commitment to quality is legendary within the industry, earning the trust from customers worldwide.

When it needs to run, make it Cat Pumps.

Product Performance Range

A wide range of pump options are available, including a variety of products that meet various industry certifications and directives.

- Flow: 0.49 to 908 lpm
- Pressure: 6.9 to 689 bar [100 to 10,000 psi]
- RPM: 100 to 3450
- Liquid Temperature: -23° to 115°C [-10° to 240°F]
- Manifold Materials: Brass, Nickel Aluminum Bronze, 304 and 316 Stainless Steel, Duplex Stainless Steel

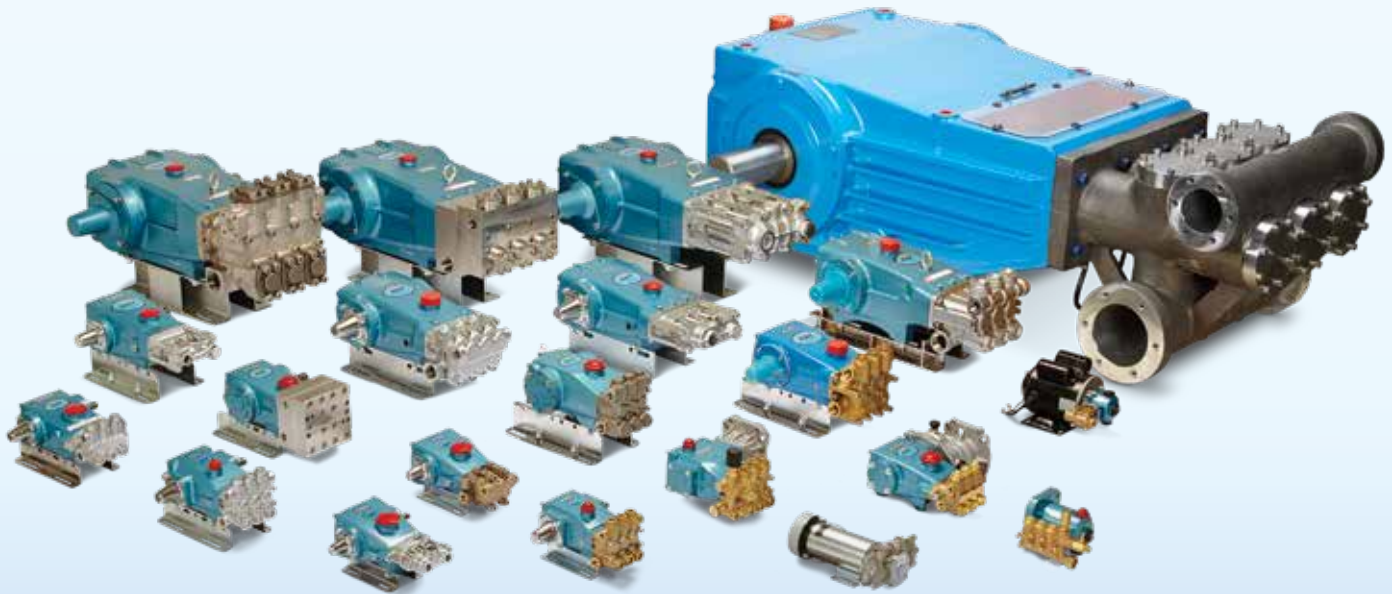

Product Ordering

Using This Catalogue

The pump sections of this catalogue are organised by drive type/flow rate/manifold materials: brass, 316 stainless steel, duplex stainless steel and nickel aluminum bronze. The model numbers listed represent standard pumps equipped with Buna-N seals and O-rings, except for specialty pumps, which are fitted with unique seals for the application.

Standard Buna-N pump seals and/or O-rings can be changed by adding a suffix to the standard model number that represents the desired new seal material.

Optional Seal and O-Ring Configurations			
MATERIAL CODE	DESCRIPTION	MAX. TEMPERATURE *	PUMP MODEL SUFFIX
NBR	Medium Nitrile (Buna-N) Seals and O-Rings	71°C [160°F]	—
FPM	Fluorocarbon (Viton®) Seals and O-Rings, Chemical Resistance	82°C [180°F]	.0110
EPDM	Ethylene Propylene Diene Monomer Seals and O-Rings	71°C [160°F]	.0220
HT	High-Temperature High-Pressure Seals	82°C [180°F]	.3000
STHT	High-Temperature High-Pressure Seals, Special Teflon® Low-Pressure Seals, NBR O-Rings	88°C [190°F]	.3400
	High-Temperature High-Pressure Seals, Special Teflon® Low-Pressure Seals, FPM O-Rings	88°C [190°F]	.3410
PTFE	Pure Polytetrafluoroethylene (Teflon®) Seals and Buna-N O-Rings	88°C [190°F]	.0700
	Pure Polytetrafluoroethylene (Teflon®) Seals and FPM O-Rings	93°C [200°F]	.0710
FFKM	Pure Polytetrafluoroethylene (Teflon®) Seals and Perfluoroelastomer O-Rings	93°C [200°F]	.0770
ST	Special blend PTFE High and Low-Pressure Seals, Buna-N O-Rings	88°C [190°F]	.4400
	Special blend PTFE High and Low-Pressure Seals, FPM O-Rings	93°C [200°F]	.4410
NBR5	Buna-N Silicone-Free Seals and O-Rings	71°C [160°F]	.6000

FPM = Fluorocarbon, EPDM = Ethylene Propylene Diene Monomer, HT = High Temp (EPDM Alternative), STHT = Special PTFE High Temperature
 PTFE = Pure Polytetrafluoroethylene, IPFE = I-Perfluoroelastomer, ST = Special PTFE, NBR = Medium Nitrile (Buna-N), NBR5 = Buna-N silicon free seals and O-Rings
 * See individual data sheet for each pump to verify actual maximum temperature allowed.
 Viton® and Teflon® are registered trademarks of DuPont Dow Elastomers.

Example

Pump model 3535 can be changed from Buna-N to either FPM or EPDM. To convert pump model 3535 from Buna-N seals and O-rings to FPM (Viton®), add the suffix (.0110) to the standard pump model number (3535.0110). Use this new number when ordering the pump.

Cat Pumps configures a number of pumps for special applications and certifications such as ATEX, CO₂, TEG, Flushed, High-Temp and others. Please contact Cat Pumps directly at (01252) 622031 for more information.

Table of Contents

Selecting Your Pump	4–5	Piston Pumps	13
Plunger Pumps	6	Specialty Pumps	14
Hollow Shaft: Brass Manifold	6	Flushed Manifold Pumps	14
Hollow Shaft: 316 Stainless Steel	7	High Temperature Pumps	15
Gearbox: Brass Manifold	7	Triethylene Glycol (TEG) Pumps, 240° F	15
Gearbox: 316 Stainless Steel Manifold	7	Washout Resistant Pumps	16
Solid Shaft: Brass Manifold	8	Bell Housing and Flexible Couplings	17
Solid Shaft: 316 Stainless Steel Manifold	8	Engineered Packages	18–19
Solid Shaft: 316 Nickel Aluminum Bronze Manifold	8		
Brass and 304 Stainless Steel	9–10		
316 Stainless Steel	11		
Duplex Stainless Steel	12		
Nickel Aluminum Bronze	12		

Selecting Your Pump

Plunger Pumps

(0.49–908 lpm, 6.9–689 bar)

Plunger pumps utilise spring-loaded closed and hydraulically opened inlet and discharge valves to direct flow through the pump manifold. At the beginning of the stroke, the plunger displaces the liquid in the manifold chamber, forcing the discharge valve open. When the plunger reaches the end of the stroke, the discharge valve closes. As the plunger rod begins its backward stroke, the inlet valve opens to allow more liquid into the manifold chamber, thereby keeping a smooth forward flow of liquid.

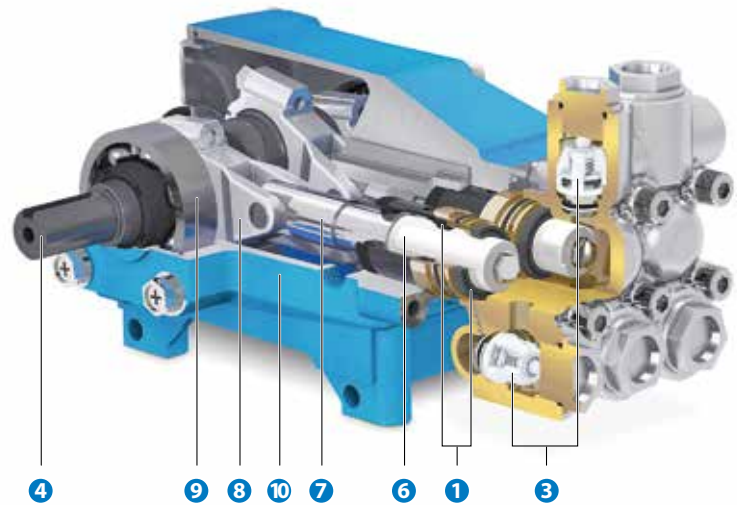

Piston Pumps

(11.4–227 lpm, 6.9–103 bar)

The design of the piston pump is for the fluid to move continually in one, smooth forward direction. This design allows greater suction capabilities and reduces the risk of cavitation provided the pump is properly primed. At the beginning of the stroke, the mechanically actuated inlet valve (and piston) will close. As the piston rod moves forward, the liquid is forced out through the discharge valves. Simultaneously, the liquid enters the pump inlet and flows in behind the inlet valve. As the piston rod begins the backward stroke, the inlet valve mechanically opens, permitting the liquid to continue its flow forward through the piston into the discharge chamber.

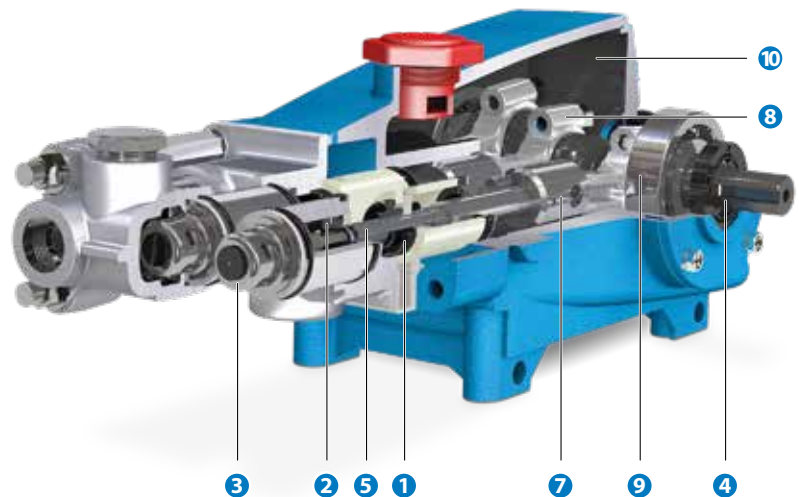

SF Series Pumps

(1.89–19.0 lpm, 6.9–172 bar)

In SF series pumps, both the inlet and discharge valves are spring-loaded closed and hydraulically opened, similar to plunger pumps, however, they have a flow-through ceramic plunger design. The continuous forward flow characteristic of piston pumps is utilised in conjunction with the packing design of the plunger pumps. These features give SF pumps both strong suction capabilities and higher pressure performances.

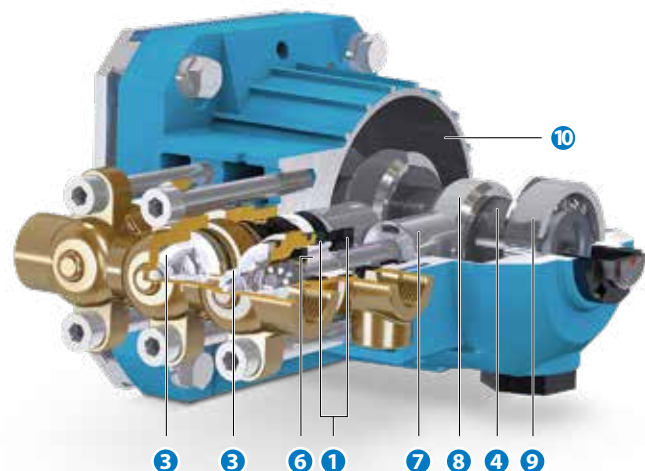

Features

- 1 Specially formulated, Cat Pumps exclusive high pressure and low pressure seals offer unmatched performance and seal life.
- 2 100% wet cup/seal design adds to service life by allowing pumped fluids to cool and lubricate the elastomers on both sides.
- 3 Stainless steel valves, seats, and springs provide corrosion-resistance, positive seating, and long life.
- 4 Chrome-moly crankshaft provides unmatched strength and surface hardness for long life.
- 5 The patented stepped piston rod with hard chrome-plated sleeve provides a durable wear surface and easy wet end servicing..
- 6 Precision-polished, solid ceramic plungers provide maximum resistance to corrosion and abrasion, extending seal life.
- 7 The high strength stainless steel plunger rods have a 360° supported crosshead providing uncompromising plunger rod alignment.
- 8 Matched oversized connecting rods are made of high strength material with exceptional bearing quality.
- 9 Oversized ball bearings or tapered roller bearings provide extended bearing life.
- 10 High Strength, light weight die cast aluminum crankcase with splash oil design allows operation at speeds as low as 100 RPM.

Quality Parts Are the Secret to Pump Longevity and Reliability

Genuine Cat Pumps parts are second to none when it comes to proven dependability and performance. Each piece is meticulously designed and manufactured, giving users the confidence that their equipment will run longer with fewer issues and less downtime over the life cycle of their pumps.



Plunger Pumps

DIRECT DRIVE, HOLLOW SHAFT, BRASS MANIFOLD

Electric Motor, 5/8" and 3/4", 56C Face



Model 4DX10ER

PUMP MODEL	MAXIMUM FLOW LPM	MAXIMUM PRESSURE		RPM	SHAFT
		BAR	PSI		
4DX03ELR	1.1	138	2000	1725	5/8"
4DX10ER	3.8	138	2000	3450	5/8"
4DX15ER	5.7	138	2000	3450	5/8"
4DX20ER	7.6	138	2000	3450	5/8"
4SP21ELR	7.9	138	2000	1750	5/8"
4DX27ER	10.3	138	2000	3450	5/8"
4SP29ELR	10.8	83	1200	1725	5/8"
4DX30ER	11.4	138	2000	3450	5/8"
2SF35ES	13.3	103	1500	3450	5/8"
2SF35GES	13.3	138	2000	3450	3/4"
2SFP500EL	19.0	34.5	500	1750	5/8"

Note: Pumps rated at 3450 rpm can operate at 1725 rpm, reducing flow by 50%.



Model 2SF22ES

DIRECT DRIVE, HOLLOW SHAFT, BRASS MANIFOLD

Electric Motor, 1 1/8", 184TC Face

PUMP MODEL	MAXIMUM FLOW LPM	MAXIMUM PRESSURE		RPM	SHAFT
		BAR	PSI		
5SP30ELU	11.4	207	3000	1750	1 1/8"
5SP30ELR*	11.4	207	3000	1750	1 1/8"
5SP35ELU	13.3	172	2500	1750	1 1/8"
5SP35ELR*	13.3	172	2500	1750	1 1/8"
5SP40ELU	15.2	138	2000	1750	1 1/8"
5SP40ELR*	15.2	138	2000	1750	1 1/8"

*"R Models" are built with an internal pressure regulator valve.



Model 5SP35ELR

DIRECT DRIVE, HOLLOW SHAFT, BRASS MANIFOLD

Engine, 3/4"

PUMP MODEL	MAXIMUM FLOW LPM	MAXIMUM PRESSURE		RPM	SHAFT	HP TYPICAL GAS ENGINE*
		BAR	PSI			
4DNX25GSI	9.5	207	3000	3450	3/4"	6.5
4DNX27GSI	10.3	207	3000	3450	3/4"	8
4DX29GUIF	11.0	179	2600	3450	3/4"	6.5
2SF30GS	11.4	138	2000	3450	3/4"	6.5
2SF35GS	13.3	138	2000	3450	3/4"	8

*Consult engine manufacturer for actual torque available at required speed.



Model 66DX40G1I

DIRECT DRIVE, HOLLOW SHAFT, BRASS MANIFOLD

Engine, 1"

PUMP MODEL	MAXIMUM FLOW LPM	MAXIMUM PRESSURE		RPM	SHAFT	HP TYPICAL GAS ENGINE*
		BAR	PSI			
66DX30G1I	11.4	276	4000	3450	1"	13
4SPX32G1I	12.2	207	3000	3450	1"	9
66DX35G1I	13.3	276	4000	3450	1"	13
66DX40G1I	15.2	276	4000	3450	1"	16
66DX50G1I	19.0	241	3500	3400	1"	13

*Consult engine manufacturer for actual torque available at required speed.

Plunger Pumps

DIRECT DRIVE, HOLLOW SHAFT, 316 STAINLESS STEEL MANIFOLD

Electric Motor, 3/8", 56C Face

PUMP MODEL	MAXIMUM FLOW LPM	MAXIMUM PRESSURE		RPM	SHAFT
		BAR	PSI		
2SF05SEEL	1.9	83	1200	1725	3/8"
2SF10SEEL	3.8	83	1200	1725	3/8"
2SF15SEEL	5.7	83	1200	1725	3/8"
2SF22SEEL	8.4	83	1200	1725	3/8"
2SFQ25SEEL	9.5	83	1200	1725	3/8"
2SFQ29SEEL	10.8	83	1200	1725	3/8"
2SFQ35SEEL	13.3	83	1200	1725	3/8"
2SFQ42SEEL	15.9	83	1200	1725	3/8"



Model 2SF22SEEL

DIRECT DRIVE, HOLLOW SHAFT GEARBOX, BRASS MANIFOLD

Engine, 3/4" and 1"

PUMP MODEL	MAXIMUM FLOW LPM	MAXIMUM PRESSURE		RPM ENGINE	SHAFT	HP TYPICAL GAS ENGINE*
		BAR	PSI			
740G1	10.6	345	5000	3465	1"	13
3CP1120G	13.3	152	2200	3600	3/4"	8
760G1	13.3	345	5000	3465	1"	16
5CP3160CSSG1	15.2	241	3500	3320	1"	13
5CP3120CSSG1	17.0	241	3500	3353	1"	16
60G1	17.0	276	4000	3450	1"	18
700G1	17.0	345	5000	3465	1"	20
5CP3150CSSG1	19.0	207	3000	3450	1"	13
5CP5135CSSG1	21.9	241	3500	3450	1"	13
5CP5140CSSG1	23.4	207	3000	3450	1"	18
5CP6120CSSG1	27.2	103	1500	3450	1"	8
5CP6180CSSG1	30.3	103	1500	3450	1"	11
56G1	30.3	172	2500	3600	1"	16
56HSG1	30.3	207	3000	3600	1"	22
7CP6165CSG1	30.3	241	3500	3265	1"	25
5CP6190G1	36.7	83	1200	3450	1"	11
7CP6110CSG1	38.0	138	2000	3400	1"	18
7CP6160CSG1	38.0	172	2500	3400	1"	22
7CP6170G1	45.4	124	1800	3264	1"	16

Note: All 1" Gearboxes are also available in 1 1/8" size (G118)

*Consult engine manufacturer for actual torque available at required speed.



Model 56G1



Model 5CP3120CSSG1

DIRECT DRIVE, HOLLOW SHAFT GEARBOX, 316 STAINLESS STEEL MANIFOLD

Engine, 3/4" and 1"

PUMP MODEL	MAXIMUM FLOW LPM	MAXIMUM PRESSURE		RPM ENGINE	SHAFT	HP TYPICAL GAS ENGINE*
		BAR	PSI			
3CP1241G	11.4	138	2000	3600	3/4"	5
3CP1211G	14.4	103	1500	3400	3/4"	5
5CPQ6241CSG1	15.2	138	2000	3600	1"	8
781G1	17.0	345	5000	3645	1"	20
5CPQ6251G1	19.0	138	2000	3600	1"	9
5CPQ6221G1	28.0	83	1200	3600	1"	8
7CP6111CSG1	38.0	138	2000	3400	1"	18

Note: All 1" Gearboxes are also available in 1 1/8" size. (G118).

*Consult engine manufacturer for actual torque available at required speed.



Model 7CP6111CSG1

Plunger Pumps

DIRECT DRIVE, SOLID SHAFT, BRASS MANIFOLD

Electric Motor – Bell Housing



Model 3CP1120



Model 5CP3160CSS

PUMP MODEL	MAXIMUM FLOW		MAXIMUM PRESSURE		RPM	SHAFT
	LPM	BAR	PSI	BAR		
5CP4110CSS	8.4	276	4000	1750	20 mm	
3CP1130	9.1	138	2200	1725	16.5 mm	
5CP3105CSS	9.5	241	3500	1750	20 mm	
5CP4112CSS	10.3	276	4000	1750	20 mm	
740	11.0	345	5000	1750	24 mm	
5CP4114CSS	12.1	276	4000	1750	20 mm	
3CP1140	13.7	152	2200	1725	16.5 mm	
5CP3110CSS	13.7	241	3500	1750	20 mm	
760	13.6	345	5000	1750	24 mm	
5CP4116CSS	14.4	276	4000	1750	20 mm	
5CP2140WCS	15.2	172	2500	1725	20 mm	
3CP1120	16.0	152	2200	1725	16.5 mm	
5CP4118CSS	16.0	276	4000	1750	20 mm	
5CP3160CSS	16.3	241	3500	1750	20 mm	
5CP4120CSS	17.0	276	4000	1750	20 mm	
60	17.9	276	4000	1750	24 mm	
700	17.9	345	5000	1750	24 mm	
5CP3120CSS	18.2	207	3000	1750	20 mm	
5CP2150W	19.0	138	2000	1725	20 mm	
5CP3150CSS	19.8	207	3000	1750	20 mm	
5CP5120	22.8	172	2500	1750	20 mm	
5CP5135CSS	22.8	241	3500	1750	20 mm	
5CP5140CSS	24.3	207	3000	1750	20 mm	
5CP6120	28.1	103	1500	1725	20 mm	
56	30.3	172	2500	1760	24 mm	
56HS	30.3	207	3000	1760	24 mm	
5CP6180CSS	31.0	103	1500	1750	20 mm	
5CP6190	38.0	83	1200	1750	20 mm	
7CP6110CS	39.9	138	2000	1750	24 mm	
7CP6160CS	40.1	172	2500	1750	24 mm	
1730	59.8	103	1500	1750	30mm	

DIRECT DRIVE, SOLID SHAFT, 316 STAINLESS STEEL MANIFOLD

Electric Motor – Bell Housing



Model 3CP1231

PUMP MODEL	MAXIMUM FLOW		MAXIMUM PRESSURE		RPM	SHAFT
	LPM	BAR	PSI	BAR		
3CP1231	8.7	138	2000	1725	16.5 mm	
784	11.0	345	5000	1750	24 mm	
3CP1241	13.7	138	2000	1725	16.5 mm	
786	13.7	345	5000	1750	24 mm	
5CPQ6241CS	15.2	138	2000	1725	20 mm	
3CP1221	16.0	138	2000	1725	16.5 mm	
781	17.8	345	5000	1750	24 mm	
3CP1211CS	19.0	117	1700	1750	16.5 mm	
5CPQ6251	19.0	138	2000	1725	20 mm	
5CPQ6281CSS	20.9	138	2000	1725	20 mm	
5CPQ6271CSS	25.1	124	1800	1725	20 mm	
5CPQ6221	28.0	83	1200	1725	20 mm	
7CP6111CS	39.9	138	2000	1750	24 mm	
1731	59.8	103	1500	1750	30 mm	



Model 277

DIRECT DRIVE, SOLID SHAFT, NICKEL ALUMINUM BRONZE MANIFOLD

Electric Motor – Bell Housing

PUMP MODEL	MAXIMUM FLOW		MAXIMUM PRESSURE		RPM	SHAFT
	LPM	BAR	PSI	BAR		
237	8.7	103	1500	1725	16.5 mm	
247	13.7	83	1200	1725	16.5 mm	
277	16.0	69	1000	1725	16.5 mm	
347	15.2	124	1800	1725	20 mm	
357	19.0	103	1500	1725	20 mm	

Plunger Pumps

SOLID SHAFT, BRASS MANIFOLD

PUMP MODEL	MAXIMUM FLOW LPM	MAXIMUM PRESSURE		RPM	SHAFT
		BAR	PSI		
5CP4110CSS	8.4	276	4000	1750	20 mm
3CP1130	9.1	138	2200	1725	16.5 mm
5CP3105CSS	9.5	241	3500	1750	20 mm
5CP4112CSS	10.3	276	4000	1750	20 mm
740	11.0	345	5000	1750	24 mm
1810**	11.4	689	10000	1500	30 mm
5CP4114CSS	12.1	276	4000	1750	20 mm
3CP1140	13.7	152	2200	1725	16.5 mm
5CP3110CSS	13.7	241	3500	1750	20 mm
760	13.7	345	5000	1750	24 mm
5CP4116CSS	14.4	276	4000	1750	20 mm
310	15.2	152	2200	950	20 mm
5CP2120W	15.2	172	2500	950	20 mm
5CP2140WCS	15.2	172	2500	1725	20 mm
3CP1120	16.0	152	2200	1725	16.5 mm
5CP4118CSS	16.0	276	4000	1750	20 mm
5CP3160CSS	16.3	241	3500	1750	20 mm
5CP3120CSS	17.0	241	3500	1645	20 mm
57	17.0	276	4000	1285	24 mm
5CP4120CSS	17.0	276	4000	1750	20 mm
60	17.9	276	4000	1750	24 mm
700	17.9	345	5000	1750	24 mm
5CP3120CSS	18.2	207	3000	1750	20 mm
310	19.0	103	1500	1190	20 mm
5CP2150W	19.0	138	2000	1725	20 mm
530	19.0	172	2500	1100	24 mm
5CP5120	19.0	207	3000	1415	20 mm
5CP3150CSS	19.7	207	3000	1750	20 mm
56	20.9	241	3500	1210	24 mm
5CP5140CSS	20.9	241	3500	1500	20 mm

** 17 – 4SS Stainless Manifolds



Model 1810



Model 310



Model 700

Selecting a Power Source

Positive displacement pumps can use a variety of different power sources, including electric motors, gas or diesel engines, hydraulic and pneumatic motors. Note: system power sources must be sized with adequate horsepower to handle the maximum system flow and pressure required.

Commonly Used Formulas

$$\text{Motor Power Required (kW)*} = \frac{\text{bar} \times \text{l/min}}{510}$$

*Standard 85% Overall Efficiency

$$\text{Hydraulic Torque Required (Nm)} = 18.7 \times \frac{\text{bar} \times \text{liters}}{\text{rpm}}$$



Model 5CP2120W

Plunger Pumps

SOLID SHAFT, BRASS MANIFOLD



Model 1570



Model 660



Model 1540E



Model 3535

PUMP MODEL	MAXIMUM FLOW LPM	MAXIMUM PRESSURE		RPM	SHAFT
		BAR	PSI		
5CP6120	22.8	110	1600	1400	20 mm
5CP5120	22.8	172	2500	1750	20 mm
5CP5135CSS	22.8	241	3500	1750	20 mm
1570	22.8	414	6000	1350	30 mm
5CP5140CSS	24.3	207	3000	1750	20 mm
5CP6180CSS	26.1	103	1500	1450	20 mm
650	26.6	207	3000	1000	30 mm
5CP6120	28.1	105	1500	1725	20 mm
5CP6190	30.3	100	1450	1450	20 mm
56	30.3	172	2500	1760	24 mm
56HS	30.3	207	3000	1760	24 mm
7CP6185CS	30.3	241	3500	1320	24 mm
5CP6180CSS	31.0	103	1500	1750	20 mm
1560	34.0	276	4000	1280	30 mm
5CP6190	38.0	83	1200	1750	20 mm
1050	38.0	152	2200	958	30 mm
660	38.0	207	3000	1429	30 mm
3550	38.0	414	6000	940	35 mm
6810**	38.0	689	10000	600	45 mm
7CP6110CS	39.9	138	2000	1725	24 mm
7CP6160CS	40.1	172	2500	1750	24 mm
7CP6170	41.6	138	2000	1450	24 mm
7CP6170	45.4	124	1800	1600	24 mm
1580	45.4	207	3000	1180	30 mm
1050	46.5	124	1800	1180	30 mm
1530	59.3	103	1500	1450	30 mm
1730	59.8	103	1500	1750	30mm
2560	60.5	207	3000	1510	30mm
1540E	73.0	83	1200	1180	30 mm
2510	76.0	138	2000	1450	30 mm
2565	76.0	172	2500	1450	30mm
3560	76.0	276	4000	1160	35 mm
2530	95.0	83	1200	1025	30 mm
3520	95.0	138	2000	870	35 mm
3560	95.0	207	3000	1450	35 mm
3570*	113.6	207	3000	1080	35 mm
3535	136.2	83	1200	800	35 mm
3535HS*	152.0	138	2000	888	35 mm
6835	152.0	207	3000	625	45 mm
3545	171.0	69	1000	765	35 mm
3545HS*	189.3	103	1500	850	35 mm
67070	189.3	138	2000	653	45 mm
67070	189.3	207	3000	653	45 mm
6760	228.0	83	1200	520	45 mm
67070*	246.0	138	2000	850	45 mm
6775	285.0	83	1200	650	45 mm

* "Intermittent duty only" is defined as operating pump at maximum-rated flow and pressure for no more than 50% of time in any given hour.

** 17-4SS Stainless Manifolds

Selecting a Drive

A variety of different drive options are offered by Cat Pumps. Most systems are belt-driven by a pulley or clutch, but there are also direct-drive options such as direct coupled, gearbox or hollow shaft direct drive.

Commonly Used Formulas

$$\text{Desired rpm} = \text{Desired lpm} \times \frac{\text{Rated rpm}}{\text{Rated lpm}} \quad \text{Pump Pulley}^* \times \frac{\text{Pump rpm}}{\text{Motor/Engine rpm}} = \text{Motor Pulley}^*$$

*Pitch Diameter

Plunger Pumps

SOLID SHAFT, 316 STAINLESS STEEL MANIFOLD

PUMP MODEL	MAXIMUM FLOW LPM	MAXIMUM PRESSURE BAR	MAXIMUM PRESSURE PSI	RPM	SHAFT
3CP1231	8.7	138	2000	1725	16.5 mm
784	11.0	345	5000	1750	24 mm
3CP1241	13.7	138	2000	1725	16.5 mm
786	13.7	345	5000	1750	24 mm
341	15.2	124	1800	1725	20 mm
5CPQ6241CS	15.2	138	2000	1725	20 mm
311	15.2	152	2200	950	20 mm
3CP1221	16.0	138	2000	1725	16.5 mm
781	17.9	345	5000	1750	24 mm
351	19.0	103	1500	1725	20 mm
3CP1211CS	19.0	117	1700	1750	16.5 mm
5CPQ6251	19.0	138	2000	1725	20 mm
5CPQ6221	22.8	138	2000	1400	20 mm
5CPQ6221	28.0	83	1200	1725	20 mm
1051	38.0	152	2200	958	30 mm
3501	38.0	345	5000	915	35 mm
7CP6111CS	39.9	138	2000	1750	24 mm
7CP6171CS	41.6	138	2000	1450	24 mm
7CP6171CSS	45.0	124	1800	1600	24 mm
1051	46.5	124	1800	1180	30 mm
3511	53.2	207	3000	800	35 mm
6811	57.0	345	5000	630	45 mm
6801	57.0	483	7000	630	45 mm
1531	59.0	103	1500	1450	30 mm
1731	59.8	103	1500	1750	30 mm
1541	73.0	83	1200	1100	30 mm
2511	76.0	103	1500	1450	30 mm
2531	95.0	83	1200	1180	30 mm
3521DHS	95.0	138	2000	870	35 mm
6821	95.0	207	3000	615	45 mm
3531DHS	136.2	83	1200	800	35 mm
3531DHS*	152.0	138	2000	888	35 mm
6831	152.0	159	2300	625	45 mm
3541DHS	171.0	69	1000	765	35 mm
6841	182.4	138	2000	615	45 mm
3541DHS*	189.3	103	1500	850	35 mm
6761	228.0	83	1200	520	45 mm

* "Intermittent duty only" is defined as operating pump at maximum-rated flow and pressure for no more than 50% of time in any given hour.



Model 311



Model 1051



Model 2531



Model 6811

Plunger Pumps

SOLID SHAFT, DUPLEX STAINLESS STEEL MANIFOLD



Model 6762

PUMP MODEL	MAXIMUM FLOW LPM	MAXIMUM PRESSURE		RPM	SHAFT
		BAR	PSI		
1051D	38.0	152	2200	958	30 mm
661D	38.0	207	3000	1429	30 mm
1051D	45.4	124	1800	1180	30 mm
6762	228.0	83	1200	520	45 mm
67102	302.8	83	1200	540	45 mm
67102	378.5	69	1000	680	45 mm
157R060	380.0	186	2700	310	100 mm
152R060	437.0	83	1200	360	100 mm
152R061	437.0	138	2000	360	100 mm
152R080	760.0	83	1200	355	100 mm
152R081	760.0	108	1560	355	100 mm
152R100	912.0	69	1000	270	100 mm



Model 152R100

BELT DRIVE, SOLID SHAFT, NICKEL ALUMINUM BRONZE MANIFOLD



Model 277

PUMP MODEL	MAXIMUM FLOW LPM	MAXIMUM PRESSURE		RPM	SHAFT
		BAR	PSI		
237	8.7	103	1500	1725	16.5 mm
277	13.3	103	1500	1420	16.5 mm
247	13.7	83	1200	1725	16.5 mm
347	15.2	124	1800	1725	20 mm
317	15.2	152	2200	950	20 mm
277	16.0	69	1000	1725	16.5 mm
357	19.0	103	1500	1725	20 mm
1057	38.0	152	2200	958	30 mm
3507HS	38.0	345	5000	915	35 mm
1057	46.5	124	1800	1180	30 mm
3517HS	53.2	207	3000	800	35 mm
2537	95.0	83	1200	1025	30 mm
3527HS	95.0	138	2000	870	35 mm
3537HS	136.2	83	1200	800	35 mm
3537HS*	152.0	138	2000	888	35 mm
3547HS	171.0	69	1000	765	35 mm
6747	182.4	138	2000	615	45 mm
6767	228.0	83	1200	520	45 mm

* "Intermittent duty only" is defined as operating pump at maximum-rated flow and pressure for no more than 50% of time in any given hour.



Model 3517

Piston Pumps

PISTON PUMPS, SOLID SHAFT, BRASS MANIFOLD

Belt Drive

PUMP MODEL	MAXIMUM FLOW LPM	MAXIMUM PRESSURE		RPM	SHAFT
		BAR	PSI		
280	11.4	69	1000	1330	16.5 mm
290	13.3	83	1200	1200	16.5 mm
333	15.2	83	1200	1070	16.5 mm
430	19.0	69	1000	1040	16.5 mm
323	19.0	103	1500	1000	20 mm
623	22.8	83	1200	850	25 mm
820	38.0	69	1000	940	25 mm
390	45.4	41	600	1200	20 mm
1010	49.4	48	700	900	25 mm
2520*	95.0	55	800	772	30 mm
6040	152.0	103	1500	500	45 mm
6020	228.0	69	1000	500	45 mm

* Available as a model 2520C with flushed inlet manifold



Model 280

PISTON PUMPS, SOLID SHAFT, 316 STAINLESS STEEL MANIFOLD

Belt Drive

PUMP MODEL	MAXIMUM FLOW LPM	MAXIMUM PRESSURE		RPM	SHAFT
		BAR	PSI		
281	11.4	69	1000	1330	16.5 mm
291	13.3	83	1200	1200	16.5 mm
331	15.2	83	1200	1070	16.5 mm
431	19.0	69	1000	1040	16.5 mm
621	22.8	83	1200	850	25 mm
821	38.0	69	1000	940	25 mm
1011	49.4	48	700	900	25 mm
6041	152.0	103	1500	500	45 mm
6021	228.0	69	1000	500	45 mm



Model 820



Model 2520



Model 6020

TECH TIP

Pump Rotation

Forward rotation (towards the manifold) is recommended to allow optimum lubrication of the crosshead area. If your installation does not allow for forward rotation, reverse rotation is acceptable if the crankcase oil is above the red dot in the oil gauge. This indicates adequate lubrication.



Forward Rotation



Reverse Rotation

Specialty Pumps

FLUSHED MANIFOLD PUMPS, SOLID SHAFT, BRASS, NICKEL ALUMINUM BRONZE Belt Drive



Model 3520C

PUMP MODEL	MAXIMUM FLOW		MAXIMUM PRESSURE		RPM	SHAFT
	LPM	BAR	PSI	BAR		
1810K**	11.4	689	10000	1500	1500	30 mm
1530C	59.0	103	1500	1450	1450	30 mm
1540EC	73.0	83	1200	1180	1180	30 mm
2520C	95.0	55	800	772	772	30 mm
3520C	95.0	138	2000	870	870	35 mm
3570C	114.0	207	3000	1080	1080	30 mm
3535C	136.2	83	1200	800	800	35 mm

Model numbers ending in "C" indicate flushed cast manifold and "K" indicate flushed block manifold.
** 17 – 45S Stainless Steel Manifolds



Model 781K

FLUSHED MANIFOLD PUMPS, SOLID SHAFT, 316 STAINLESS STEEL MANIFOLD Belt Drive

PUMP MODEL	MAXIMUM FLOW		MAXIMUM PRESSURE		RPM	SHAFT
	LPM	BAR	PSI	BAR		
341C	15.2	124	1800	1725	1725	20 mm
311C	15.2	152	2200	950	950	20 mm
781K	17.9	345	5000	1750	1750	24 mm
351C	19.0	103	1500	1725	1725	20 mm
1051C	38.0	152	2200	958	958	30 mm
661C	38.0	207	3000	1429	1429	30 mm
3501C	38.0	345	5000	915	915	35 mm
7CP6111CCS	39.9	138	2000	1750	1750	24 mm
7CP6171CCS	41.6	138	2000	1450	1450	24 mm
7CP6171CCS	45.0	124	1800	1600	1600	24 mm
1051C	46.5	124	1800	1180	1180	30 mm
3511C	53.2	207	3000	800	800	35 mm
6811K	57.0	345	5000	600	600	45 mm
6801K	57.0	483	7000	600	600	45 mm
1541C	73.0	83	1200	1180	1180	30 mm
2531C	95.0	83	1200	1025	1025	30 mm
3521CHS	95.0	138	2000	870	870	35 mm
6821K	95.0	207	3000	615	615	45 mm
3531CHS	136.2	83	1200	800	800	35 mm
6831K	152.0	159	2300	625	625	45 mm
3541CHS	171.0	69	1000	765	765	35 mm
6841K	182.4	138	2000	615	615	45 mm
6861K	228.0	83	1200	520	520	45 mm
67102C	378.5	69	1000	680	680	45 mm

Model numbers ending in "C" indicate flushed cast manifold and "K" indicate flushed block manifold.



Model 1051C

FLUSHED MANIFOLD PUMPS, SOLID SHAFT, DUPLEX STAINLESS STEEL MANIFOLD Belt Drive



Model 67102

PUMP MODEL	MAXIMUM FLOW		MAXIMUM PRESSURE		RPM	SHAFT
	LPM	BAR	PSI	BAR		
152R060C	437.0	83	1200	360	360	100 mm
152R080C	760.0	83	1200	355	355	100 mm
152R100C	912.0	69	1000	270	270	100 mm

Model numbers ending in "C" indicate flushed cast manifold and "K" indicate flushed block manifold.

Specialty Pumps

HIGH-TEMPERATURE AND INTERMITTENT RUN DRY; .3400 SERIES,

The “.3400” Series pumps feature specially blended seals and V-packings, expanding pump operating performance to 88° C [190° F] . This modification also allows the pump to run intermittently dry without damaging the seals. Standard plunger pumps can be fitted with these specially blended seals. Ordering this configuration requires adding .3400 to pump base model. For example, a 310 pump fitted with high temperature seals will be 310.3400. Contact Cat Pumps for additional information.



Model 1051.3400

HIGH-TEMPERATURE/ TRIETHYLENE GLYCOL (TEG) PUMPS, SOLID SHAFT, BRASS MANIFOLD Belt and Bell Housing Drive; 115°C [240° F]

PUMP MODEL	MAXIMUM FLOW LPM	MAXIMUM PRESSURE		RPM	SHAFT
		BAR	PSI		
3CP1130.44101	9.1	152	2200	1725	16.5 mm
5CP3105CS.44101	9.5	241	3500	1725	20 mm
3CP1140.44101	13.7	152	2200	1725	16.5 mm
5CP2120W.44101	15.2	172	2500	950	20 mm
5CP2140CS.44101	15.2	172	2500	1725	20 mm
3CP1120.44101	16.0	152	2200	1725	16.5 mm
5CP2150W.44101	19.0	138	2000	1725	20 mm
5CP5135CSS.44101	22.8	241	3500	1750	20 mm
5CP6120.44101	28.0	103	1500	1725	20 mm
1050.44101	38.0	152	2200	958	30 mm
1050.44101	46.5	124	1800	1180	30 mm
1530.44101	59.0	103	1500	1450	30 mm
1540E.44101	73.0	83	1200	1180	30 mm
2510.44101	76.0	138	2000	1450	30 mm
2530.44101	95.0	83	1200	1025	30 mm
3520.44101	136.0	83	1200	870	35 mm
3535.44101	136.0	83	1200	800	35 mm



Model 3CP1120.44101

HIGH-TEMPERATURE/TEG PUMPS, SOLID SHAFT, 316 STAINLESS STEEL MANIFOLD Belt and Bell Housing Drive; 115° C [240° F]

PUMP MODEL	MAXIMUM FLOW LPM	MAXIMUM PRESSURE		RPM	SHAFT
		BAR	PSI		
3CP1231.44101	8.7	138	2000	1725	16.5 mm
3CP1241.44101	13.7	138	2000	1725	16.5 mm
5CPQ6241.44101	15.2	138	2000	1725	20 mm
3CP1221.44101	16.0	138	2000	1725	16.5 mm
5CPQ6251.44101	19.0	138	2000	1725	20 mm
5CPQ6221.44101	22.8	138	2000	1400	20 mm
1051.44101	38.0	152	2200	958	30 mm
1051.44101	46.5	124	1800	1180	30 mm
1531.44101	59.0	103	1500	1450	30 mm
1541.44101	73.0	83	1200	1180	30 mm
3521DHS.44101	95.0	138	2000	870	35 mm
2531.44101	95.0	83	1200	1025	30 mm
3531DHS44101	136.2	83	1200	800	35 mm
3531DHS.44101	152.0	138	2000	888	35 mm



Model 1051.44101

Specialty Pumps

WASHOUT RESISTANT, B SERIES, SOLID SHAFT, SPECIAL BRASS MANIFOLD, VEHICLE WASH
Belt and Bell Housing Drive



Model 310B

PUMP MODEL	MAXIMUM FLOW LPM	MAXIMUM PRESSURE		RPM	SHAFT
		BAR	PSI		
340B	15.2	124	1800	1725	20 mm
310B	15.2	152	2200	950	20 mm
5CP2120B	15.2	172	2500	950	20 mm
5CP2140BCS	15.2	172	2500	1725	20 mm
350B	19.0	103	1500	1725	20 mm
5CP2150B	19.0	138	2000	1725	20 mm

ATEX Pumps

We are pleased to announce that Cat Pumps offers a full range of pumps that meet the ATEX directive for pumps used in an explosive atmosphere. The ATEX directive addresses what equipment is permitted to be used in an environment with an explosive atmosphere.

The following pump series comply with the ATEX directive for Group 2, Category 2, and Zones 1 and 2. This Group 2 includes Zones G [1 & 2].



Model 1051

Pump Series

- 3CP* Plunger Pumps
- 3 Frame* Plunger Pumps
- 5CP* Plunger Pumps
- 5 Frame* Plunger Pumps
- 7CP* Plunger Pumps
- 7 Frame* Plunger Pumps
- 8 Frame* Plunger Pumps
- 15 Frame Plunger Pumps
- 18 Frame Plunger Pumps
- 25 Frame Plunger Pumps
- 28 Frame Plunger Pumps
- 35 Frame Plunger Pumps
- 38 Frame Plunger Pumps
- 60 Frame Plunger Pumps
- 68 Frame Plunger Pumps

* Excludes models equipped with gearbox

Bell Housings and Flexible Couplings



Cat Pumps bell housings and couplings offer a simple and efficient solution for connecting your pump to an electric motor. Using a conventional drive coupling for transmission this method of assembly offers the user a compact pumping system. Our standard range will fit 90 to 160 frame motors with ATEX option available. Take advantage of the convenience of direct-drive pumps with a prompt delivery from Cat Pumps.

Features and Benefits

- Pump mounts directly onto motor, eliminating the need for drive belts, guards and baseplate
- Fits to standard metric motors with B34 C-D in foot and flange face
- Prevents contact with moving parts, improving personal safety
- Compact design reduces installation space
- Simple self-alignment minimises side-loading on pump and motor shaft, extending bearing life
- Special finger-type coupling designed for extended life; tolerates higher temperatures and high running speeds
- All fixing screws included

Applications

- Pressure Washers
- Self-Serve Car Wash
- Car Wash Prep Units
- Washdown Systems
- Salt Water Desalination/SWRO
- Misting/Cooling/Fogging Systems
- Industrial High-Pressure Power Units



Engineered Packages

You Define. We Design and Deliver.



Custom Engineered to Meet Your Application Demands



Cat Pumps is an industry leader in providing customers with quality engineered packages to meet a wide range of application needs. By selecting an engineered package, customers eliminate the hassle and expense of designing, multiple source buying, fabricating and testing. Our knowledgeable and helpful technical sales team assists with proper component selection as well as installation, operation and maintenance support.

All systems are designed, built and pressure tested to verify performance. To begin the quoting process, contact us at +44 (0) 1252 622031 or email sales@catpumps.co.uk to start your quote today.

With thousands of installations running around the world, Cat Pumps is the supplier of choice for engineered packages.

Contact Sales on 012502 622031 or email sales@catpumps.co.uk to talk to us about your engineered package enquiry.



Engineered Packages

System Configuration

With extensive experience building thousands of systems, Cat Pumps can help determine the best configuration for any application.

✓ Base

System design starts with choosing the base that best fits the application. Numerous base configurations are available to meet space, portability, sound and material demands.

- Standard • Vertically Stacked • Portable • Enclosed • Multiple Pump

✓ Power Source

A qualified technical staff with extensive experience can assist in recommending the correct product for any power source available.

- Electric – 1-Phase, 3-Phase; 50 or 60Hz

✓ Drive Package

A wide variety of drive packages are available to complement any power source of choice.

- Belt • Direct Drive • Gearbox • Flexible Coupling/Bell Housing • Clutch

✓ Accessories

Choose from hundreds of high-quality genuine Cat Pumps accessories for optimum system performance and life.

- Regulator • Unloader • Relief / Pop-off Valve • Pressure Gauge
- Pulsation Dampener • Inlet Stabilizer • Inlet Filter / Strainer • Guns • Oil

Cat Pumps Advanced Options



Ask about the wide variety of advanced options, designed to help provide maximum system performance and protection.

Options include:

- Variable Frequency Drives
- PID Loop (varies speed of pump to maintain system pressure)
- Multiple Pump Systems
- Low-Pressure Seal Monitors
- Auto Shutdowns (Temperature and Low Inlet Pressure)
- Interconnecting Pipework

Other options to suit your application needs are available upon request. Contact Cat Pumps for more information.





Cat Pumps occupies over 149,000 sq. ft. at its world headquarters in Minneapolis, MN.

Cat Pumps Locations

**Cat Pumps Corporation—
World Headquarters**
1681 94th Lane Northeast
Minneapolis, MN 55449
USA

P: (763) 780-5440
F: (763) 780-2958
info@catpumps.com
www.catpumps.com

Territories Served
U.S., Canada

International Division
P: (763) 780-5440
F: (763) 785-4329
intlsales@catpumps.com
www.catpumps.com

Territories Served
Africa, Asia, Australia, Central and
South America, Mexico, Middle East,
New Zealand, Turkey



Cat Pump (U.K.) Ltd.
1 Fleet Business Park, Sandy Lane
Church Crookham
FLEET, Hampshire GU52 8BF
England

P: +44 (0) 1252 622031
F: +44 (0) 1252 626655
sales@catpumps.co.uk
www.catpumps.co.uk

Territories Served
U.K. and Ireland

Cat Pumps International N.V.
Heiveldekens 6A
2550 Kontich
Belgium

P: 32 3 450 71 50
F: 32 3 450 71 51
cpi@catpumps.be
www.catpumps.be

Territories Served
Western Europe (except U.K.,
Germany, and Austria)

Cat Pumps Deutschland GmbH
Buchwiesse 2, D-65510
Idstein
Germany

P: +49 6126 9303 0
F: +49 6126 9303 33
catpumps@t-online.de
www.catpumps.de

Territories Served
Austria, Commonwealth of Independent
States (CIS), Germany and Eastern Europe

SALES, DISTRIBUTION, SERVICE Call today for product and application assistance. (01252) 622031 or visit us at www.catpumps.co.uk



CAT PUMPS (U.K.) LTD.
1 FLEET BUSINESS PARK, SANDY LANE, CHURCH CROOKHAM
FLEET, HAMPSHIRE GU52 8BF, ENGLAND
P: +44 (0) 1252 622031 • F: +44 (0) 1252 626655
sales@catpumps.co.uk • www.catpumps.co.uk